



INDEF

INDEF MARKETING SERVICES LTD.





INDEF

## INDEF MARKETING SERVICES LTD.

Hercules Hoists Ltd. a company established in 1962, has now become a corporate entity, renowned in the manufacture of material handling equipment. A diverse product range that encompasses Chain Pulley Blocks, Electric Hoists, Cranes, etc. that fulfills the storage, retrieval and material handling needs of companies around the world.

An integral part of the eminent Bajaj group, one of India's top-notch business houses, the company has continuously surpassed its standards of excellence.



Its reputation of trust and reliability is bolstered not only by its ISO 9000-2000 Certification, but also by the testimony of its clientele. Hercules Hoists Ltd. has set up a modern manufacturing facility at Mulund, Mumbai, equipped with the latest technological know-how- CNC machines, gear cutting machines, broaching machines, etc. Every product that emerges from its production line bears the INDEF mark of quality and reliability.

Besides, the Company has instituted a dedicated marketing division with a network of 45 authorized marketing associates, 100 dealers, service Agents and Liaisoning agents. It has appointed business facilitators at several strategic locations to facilitate business transactions and to gauge customer application needs.

### Manufacturing Excellence at Hercules Hoists Ltd.

HHL has set up a sprawling factory at Mulund, Mumbai where it manufactures its range of products. It utilizes a state of the art Machine shop, Ultra modern assembly lines and Accurate testing equipment. With a workforce of over one hundred workmen and 87 staff comprising officers and engineers, the Company enforces strict quality control at every stage of the manufacturing process - right from selection of raw material to the inspection of the finished product

### Marketing Strategies for a Global Reach

Towards the goal of reaching a global market, Hercules Hoists Ltd. has specially set up a Marketing division, headed by General Manager-Marketing and supported by Business Facilitators station at strategic locations for direct interaction with customers. Its products are now marketed through out India by 45 authorized marketing associates and network of dealers, representatives and liaison agents. It registered sales of nearly Rs. 300 million for the current financial year, making it the undisputed No. 1 brand with the largest market share. The Company has also made its mark on the global scene by supplying material handling equipment to European, Middle East, Africa and South East Asian Countries.



INDEF

## INDEF MARKETING SERVICES LTD.



All purpose, Safe and Compact Hoists  
Capacity - 50 Kg to 5000 Kg.

- Overload slipping clutch  
Safety Assured
- Precision Machined R Case hardened alloy Steel Gears and load chain wheel  
Long life, noiseless operation
- Built in electrical control panel  
Ready to use
- Ergonomically designed pendent control  
Easy of usage

### Heavy Duty Wire Rope Hoists

- Planetary gear box  
Giving smooth & low noise operation
- Ring type rope guide  
Rugged design
- Imported Brake motor  
Long life multispeed options
- Seamless Tube drums  
Long life engineered product





INDEF

## INDEF MARKETING SERVICES LTD.



### Robust Chain Pully Block

- Rugged German design, in use for more than 30 years  
**Assured Reliability**
- Double Ball Bearing Supported Load Wheel  
**Smooth Operation**
- Precision Machined Case hardened alloy Steel Gears  
**Long life, noiseless operation**
- Fully Pocketed S. G. Iron Cast Load Chain Wheel  
**Long life, Safe and smooth running**

### Ratchet Lever Hoist

- Robust steel construction  
**Sturdy design**
- Low operating effort  
**Less fatigue to operator**
- Superior asbestos free brake  
**For safe operation**
- Light weight and compact  
**Ease of handling**





INDEF

## INDEF MARKETING SERVICES LTD.

### Pulling & Lifting Machine

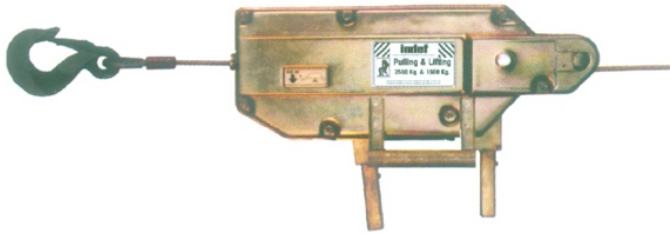

- Alloy Steel Heat Treated Jaws  
Long Life, Prevents Slipping.
- Shear Pin in Forward/Lifting Lever  
Prevents over Loading, Safety ensured.
- Ergonomically Designed Lever  
Ease of Operation.
- Rugged and Light Weight Steel Body  
Assured reliability in difficult conditions, easier to handle

### Automated Storage & Retrieval Cranes

- Fast Speed Operation  
Very high throughput rate more efficiency
- Use of Telescopic Forks  
Very narrow aisle operation, Saves Floor Space
- Serves upto 15m Rack height  
Increased Space Utilization
- Cabin Controlled Operation  
Makes Storage and Retrieval quick,  
also enables order Picking.

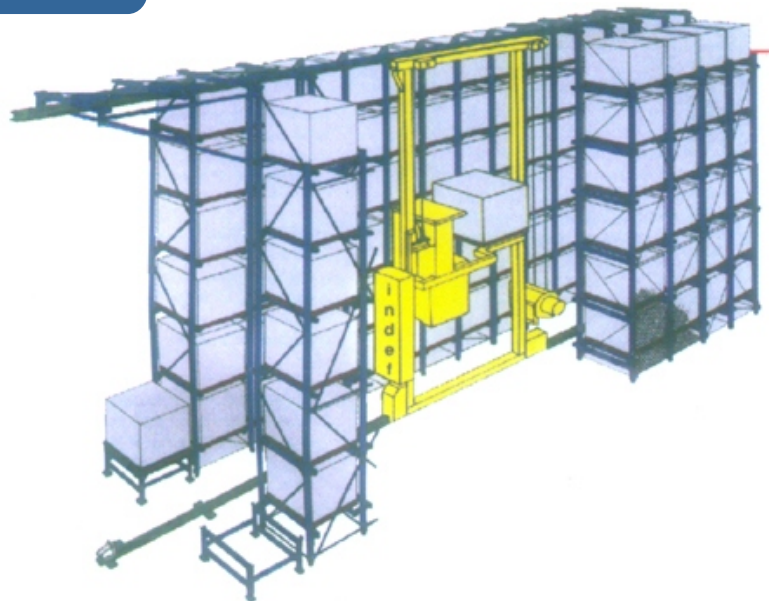



INDEF

INDEF MARKETING SERVICES LTD.

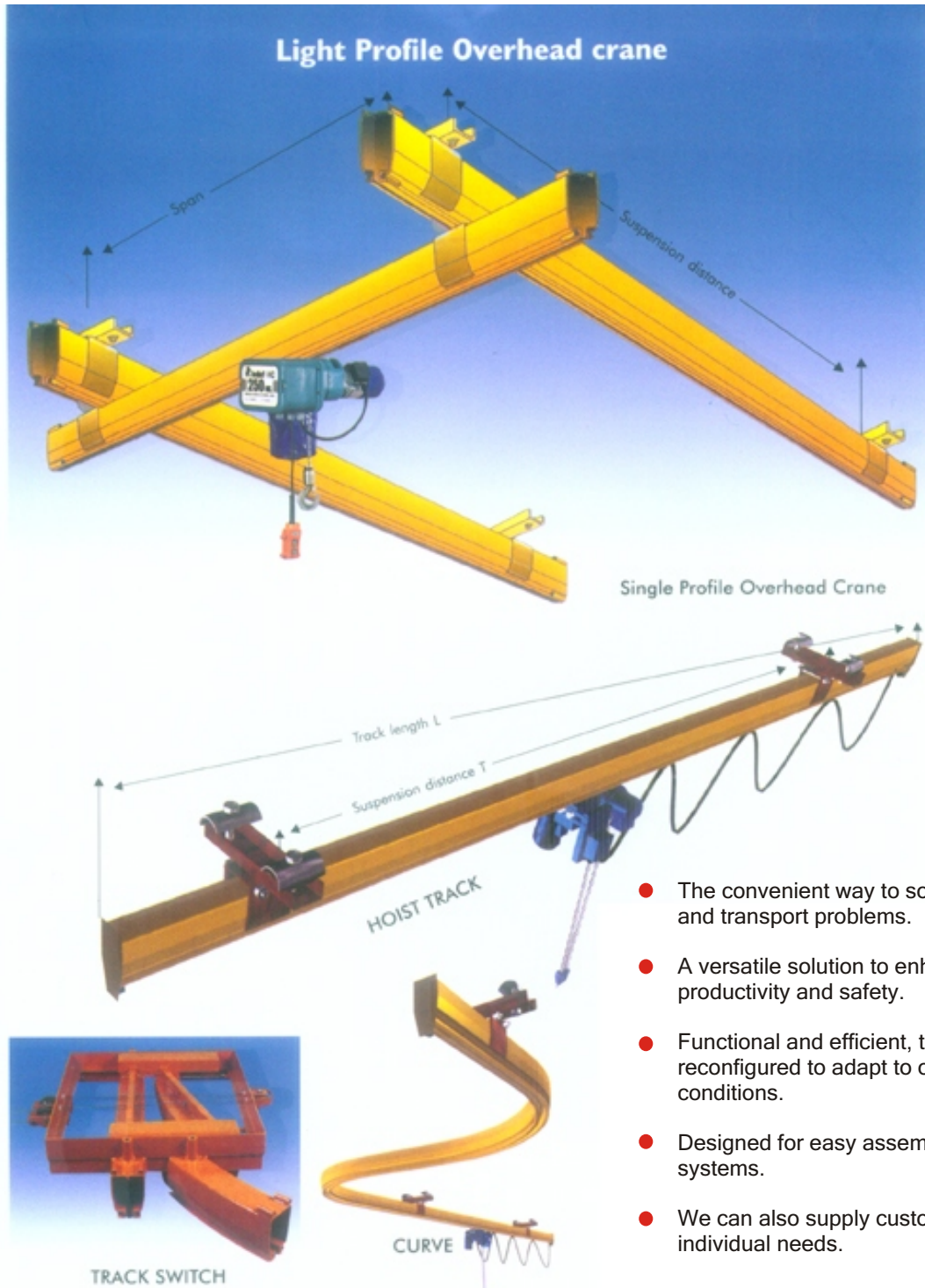

- The convenient way to solve local lifting and transport problems.
- A versatile solution to enhance productivity and safety.
- Functional and efficient, the system can be reconfigured to adapt to changing conditions.
- Designed for easy assembly of specific systems.
- We can also supply custom parts to suit individual needs.

Marketed in India by :  
INDEF MARKETING SERVICES LTD.



INDEF

108, Minerva Estate, Mulund (W),  
Mumbai-400080. India.  
Tel. : +91(22)5624214, 5680381,  
Fax : +91(22)5683933  
Website : <http://www.e-indef.com>  
e-mail : [indef@bom5.vsnl.net.in](mailto:indef@bom5.vsnl.net.in)  
Manufactured by :  
Hercules Hoists Ltd.

Manufactured by :  
Hercules Hoists Ltd.

